

## HTS Series 8 Wall Pack (LWP)

Energy Efficient LED Lighting

320-400+ Watt replacement

### FEATURED HIGHLIGHTS

- \*Unlimited application possibilities due to retrofitting
- \*Saves up to 79% of energy consumption
- \*100,000 hour lifespan 5yr. Manufacturers registered warranty
- \*Return on Investment between 18 to 40 months.

### ENVIRONMENTAL FEATURES

- \*Contains no mercury or lead
- \*Does not produce UV rays
- \*Does not attract insects
- \*Directional light means no light pollution

### ELECTRICAL SPECIFICATIONS

- \*47 to 63 Hertz ac line power voltage from 90 VAC RMS to 277 VAC RMS
- \*Available to 480 VAC
- \*Nominal operating efficiency is 85% typical at 230 VAC and maximum load
- \*Driver provides surge protection at 305 VAC
- \*Power distributed to onboard drivers per six LED lights

## SPECIFICATIONS

\*\*UL and CUL rated #E326977

\*\*MADE IN THE U.S.A

Our HTS 8 Wall pack fixtures utilize the HTS-8 boards for optimal lighting. Its superior heat management and compact design make it ideal for replacement fixtures, 10+ years maintenance free service.

### OUTPUT SPECIFICATIONS

- \*Cree High Output LEDs
- \*Number of Lights 36
- \*Source power 88 Watts
- \*CRI 74
- \*Lumens 7600 at 100%
- \*Efficacy 81.85 LM/W
- \*Junction Temperature <60°C
- \*IESNA Tested LM79 & LM80
- \*Operating Range -30°C to 70°C
- \*Nominal Lumens per watt 92
- \*EMC: Complaint to 47 CFR, part 2, 15

### ASSEMBLY

- \*Metal Core Board
- \*One piece aluminum heat sink dissipates heat
- \*Vibration resistant
- \*ASTM and NEMA Tested

### APPLICATIONS

- \*Wall packs
- \*Exterior
- \*Safety
- \*Security

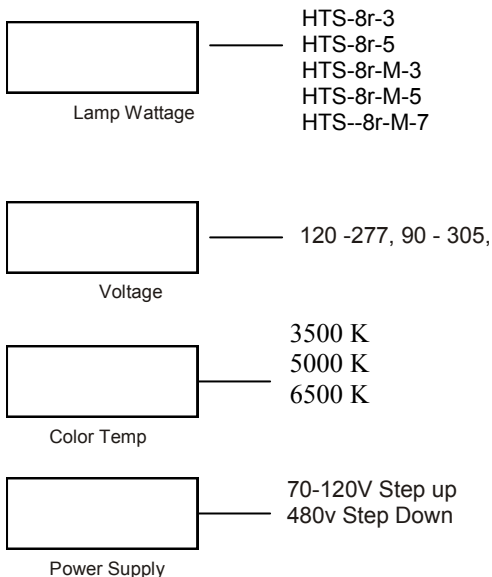

### Dimensions

Weight: 23 lbs. (with LED Board and power supply)

18.2" x 9.4" x 9"

Issue Date: 5/20/11

Supersede Date: 4/22/11

